



XS Handlaufbeslag

Bestehend aus:

- XS Gehäuse ø15 mm
- XS Gewindestift mit M10, SW5
- XS Stahldübel ø10 mm

XS Handrail Connector

Consisting of:

- XS Steel Housing ø15 mm
- XS Grub Screw M10, SW5
- XS Steel Dowel ø10 mm

Beschreibung

- Zum stufenlosen Verbinden von Handläufen
- Kompletter Beschlag aus Stahl
- Kein seitliches Verschieben möglich
- Überdurchschnittlich hohe Festigkeitswerte
- Leichte Montage für den Endverbraucher
- Made in Germany

Specification

- For connecting handrails – freely-adjustable
- Completely made of steel
- No side movements possible
- Higher than average rate of firmness
- Easy to mount
- Made in Germany

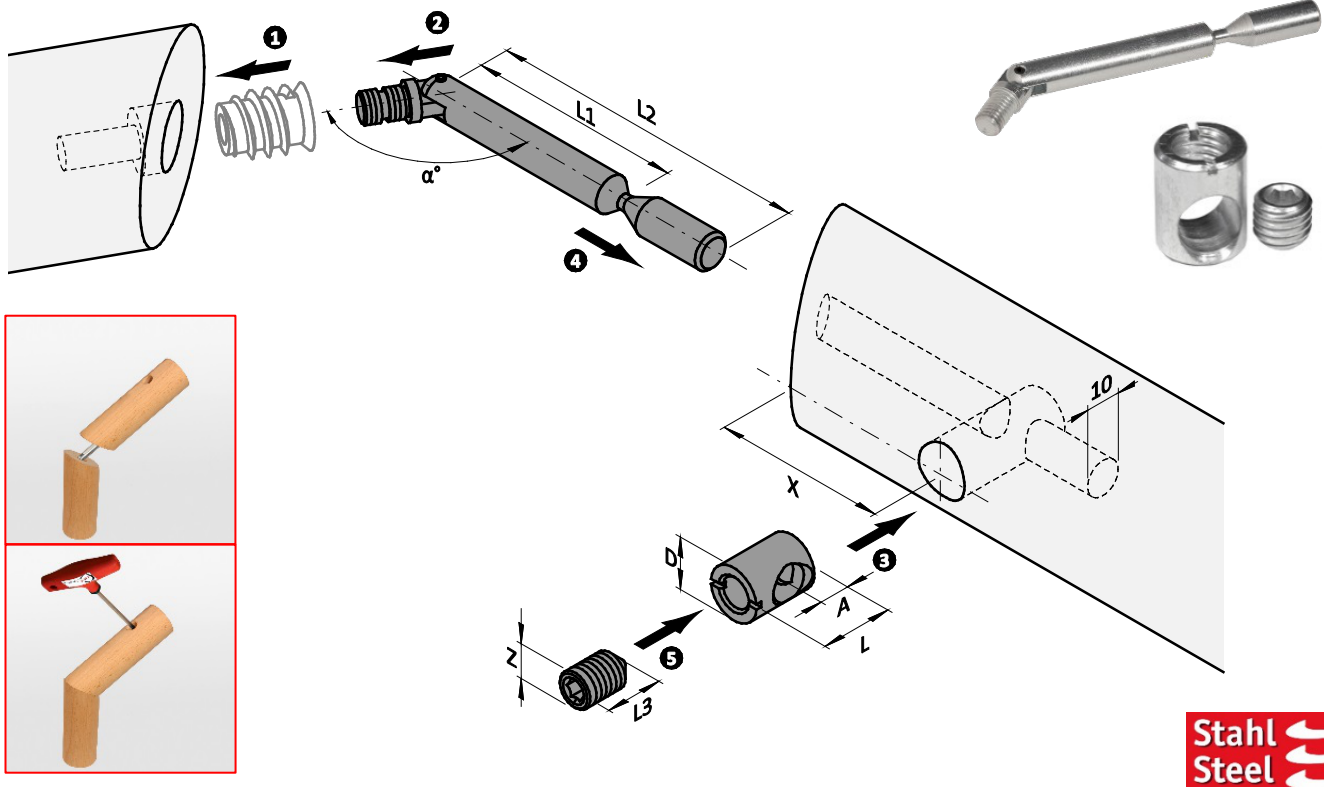

Gehäuse / Housing ø15 mm					
Artikel-Nr. order-no.	Material M	L	A	D	VE PU
D01035	20	17	10,0	15	100
D01002	22	19	12,0	15	100
D01003	24-28	21	14,0	15	100
D01004	30	28	13,0	15	100

Gew.-Stift / Grub Screw M10			
Artikel-Nr. order-no.	L3	Z	VE PU
D01036	10,0	SW5	100
D01005	16,0	SW5	100
D01005	16,0	SW5	100
D01005	16,0	SW5	100

Stahldübel / Steel Dowel ø10 mm				
Artikel-Nr. order-no.	L1	L2	d	VE PU
D02040	89,5	109,0	M8x11	10
D02041	89,5	109,0	M8x11	2

Hinweis / Please note

X: Passende Gewindemuffen M8 auf S. 52 / X: Matching Inserts M8 on page 52

M: Materialstärke; Alle Abmessungen in mm / M: Board thickness; All dimensions in mm



XS Handlaufbeschlagn

Bohrbild

XS Handrail Connector

Drilling distances

Beschreibung

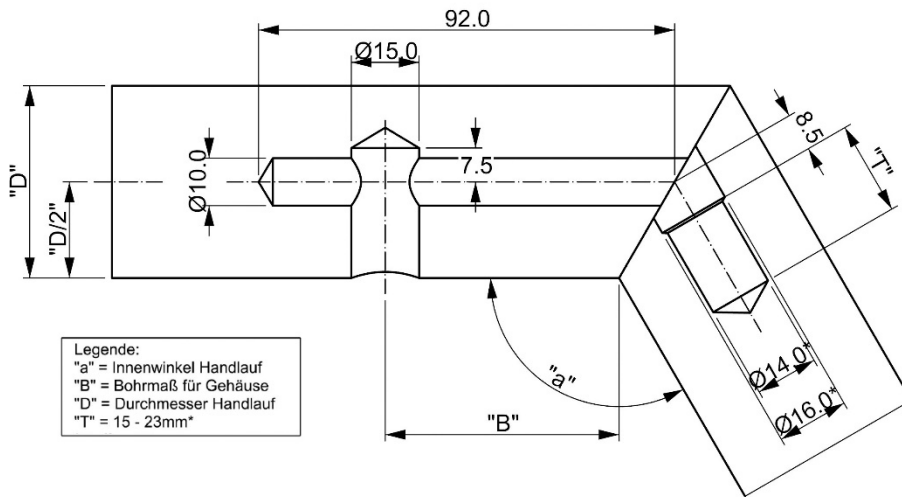

Bohrmaß „B“ = „X“ (theor.) in mm für Gelenkdübel Handlauf ø10/15mm (Toleranz: -0,5/+1,0mm)

Ein Probeanschlag wird empfohlen!

Drilling distance „B“ = „X“ (theor.) in mm for Mitre Dowel Handrail ø10/15mm (Tolerance: -0,5/+1,0mm)

A test with a sample is recommended!

Gewindemuffe M8 auswählen, z. B. D01128(siehe S. 52). / Choose Insert M8 e.g. D01128(see p. 52).

Winkel α	Handlaufdicke / handrail thickness (mm)												
	30,0	32,5	35,0	37,5	40,0	42,5	45,0	47,5	50,0	52,5	55,0	57,5	60,0
55°	37,0	35,0	32,5	30,0	27,5	25,0	23,0	20,5	18,0	15,5	13,0	11,0	8,5
60°	40,0	38,0	35,5	33,5	31,5	29,0	27,0	25,0	22,5	20,5	18,5	16,0	14,0
65°	42,5	40,5	38,5	36,5	34,5	32,5	30,5	28,5	27,0	25,0	23,0	21,0	19,0
70°	44,5	43,0	41,0	39,0	37,5	35,5	34,0	32,0	30,5	28,5	26,5	25,0	23,0
75°	46,5	45,0	43,0	41,5	40,0	38,5	36,5	35,0	33,5	32,0	30,0	28,5	27,0
80°	48,0	46,5	45,0	43,5	42,0	40,5	39,0	37,5	36,0	34,5	33,0	32,0	30,0
85°	49,5	48,5	47,0	45,5	44,0	43,0	41,5	40,0	38,5	37,5	36,0	34,5	33,5
90°	51,0	50,0	48,5	47,5	49,0	45,0	43,5	42,5	41,0	40,0	38,5	37,5	36,0
95°	52,5	51,0	50,0	49,0	47,5	46,5	45,5	44,0	43,0	42,0	41,0	39,5	38,5
100°	53,5	52,5	51,5	50,5	49,0	48,0	47,0	46,0	45,0	44,0	43,0	42,0	41,0
105°	54,5	53,5	52,5	51,5	50,5	49,5	48,5	48,0	47,0	46,0	45,0	44,0	43,0
110°	55,5	54,5	53,5	53,0	52,0	51,0	50,0	49,5	49,0	47,5	46,5	46,0	45,0
115°	56,5	55,5	55,0	54,0	53,5	52,5	51,5	51,0	50,0	49,5	48,5	47,5	47,0
120°	57,5	56,5	56,0	55,0	54,5	53,5	53,0	52,5	51,5	51,0	50,0	49,5	48,5
125°	58,0	57,5	57,0	56,0	55,5	55,0	54,5	53,5	53,0	52,5	51,5	51,0	50,5
130°	59,0	58,5	58,0	57,5	56,5	56,0	55,5	55,0	54,5	54,0	53,0	52,5	52,0
135°	60,0	59,5	59,0	58,0	57,5	57,0	56,5	56,0	55,5	55,0	54,5	54,0	53,5
140°	60,5	60,0	59,5	59,0	58,5	58,5	58,0	57,5	57,0	56,5	56,0	55,5	55,0
145°	61,5	61,0	60,5	60,0	59,5	59,5	59,0	58,5	58,0	57,5	57,5	57,0	56,5
150°	62,0	61,5	61,5	61,0	60,5	60,5	60,0	59,5	59,5	59,0	58,5	58,5	58,0
155°	62,5	62,5	62,0	62,0	61,5	61,5	61,0	60,5	60,5	60,0	60,0	59,5	59,0
160°	63,5	63,0	63,0	62,5	62,5	62,5	62,0	62,0	61,5	61,5	61,0	61,0	60,5
165°	64,0	64,0	63,5	63,5	63,5	63,0	63,0	63,0	62,5	62,5	62,5	62,0	62,0
170°	64,5	64,5	64,5	64,5	64,5	64,0	64,0	64,0	64,0	63,5	63,5	63,5	63,5
175°	65,5	65,5	65,0	65,0	65,0	65,0	65,0	65,0	65,0	65,0	65,0	64,5	64,5
180°	66,0	66,0	66,0	66,0	66,0	66,0	66,0	66,0	66,0	66,0	66,0	66,0	66,0